

ArcelorMittal Multi Part Integration®

Solution for a light steel Body in White with simplified manufacturing operations



Global Research and Development
April 2023

$$\frac{\partial f_{i,j}(\vec{x}, \vec{c})}{\partial x_i} = \sum_{k \neq i} c_{k,j}$$

A hand holding a grey marker is writing 'R&D' in red above the word 'STEEL' in large, bold, black capital letters on a whiteboard. The background of the whiteboard is a light grey gradient.

Jérôme Favero – Head of Automotive Steel Solutions, ArcelorMittal Global R&D
J.Wilsius, B.Sarre, H. Liu (Global R&D Montataire)
K.Luttenschlager (AMTB)

ArcelorMittal Multi Part Integration™

Concept introduction

- Meeting the new automotive trends:
 - Simplification
 - Modularity
 - Electrification
 - Sustainability
- ArcelorMittal Multi Part Integration™ combining:
 - High-tech laser welded blanks
 - Latest press hardenable steel (PHS) products to form complex parts (Usibor® 2000 & Ductibor® 1000)
 - Large size parts to integrate many components

Additional added value to OEMs in addition to crash resistance and mass & cost savings.

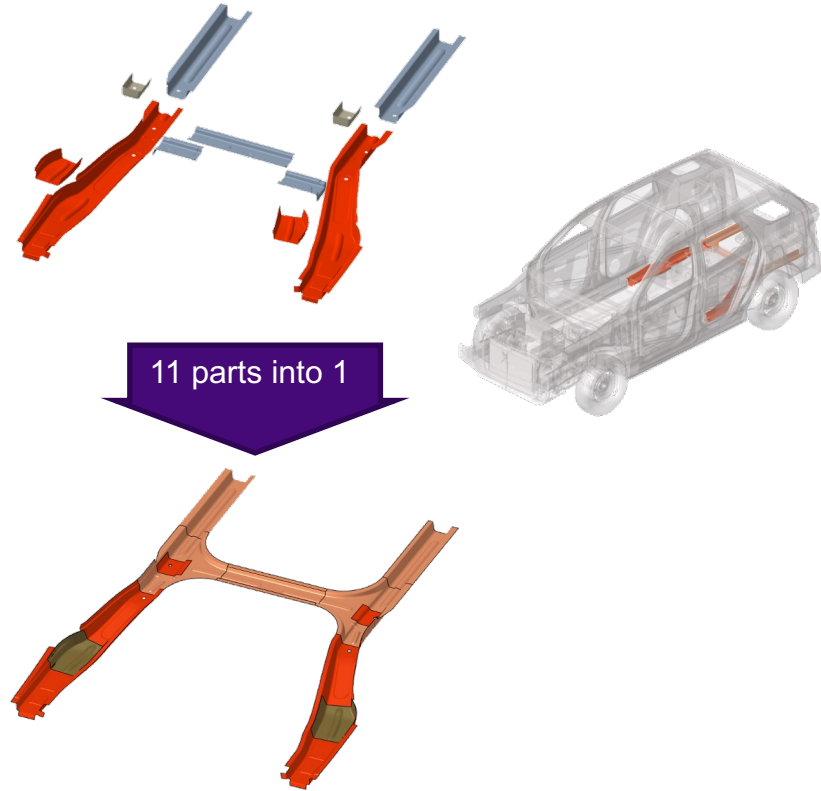

ArcelorMittal Multi Part Integration™

Interesting gains on manufacturing operations (H-Frame scope)

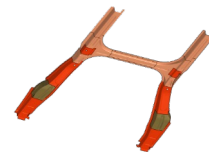

Aspect	Gain
Part count reduction	1 part instead of 11
Assembly spotwelds reduction	- 136 spot welds suppressed
Part mass reduction	10% weight saving with new PHS
Economical impact	-29% CAPEX
CO _{2eq} reduction	-18% CO_{2eq} savings -27% CO_{2eq} savings with Usibor® 1500 AS with XCarb® (45% if scrap credit not considered)
Hour of labor per Vehicle (at the rear module level)	- 40%
Workshop area reduction	-44% floor size assembly plant (-23% global)

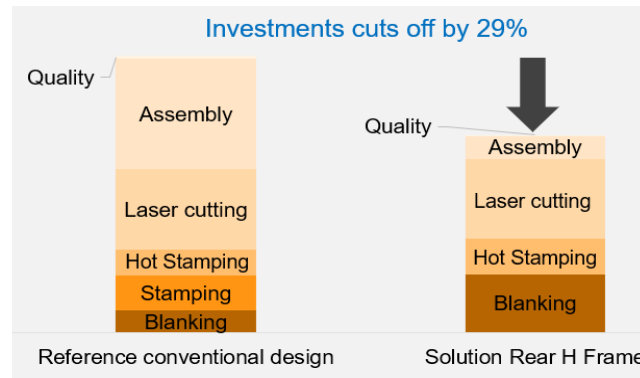
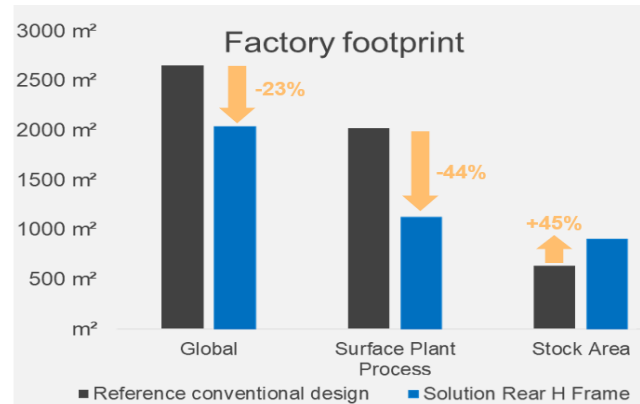

ArcelorMittal Multi Part Integration™

From the Engineering to the Prototype

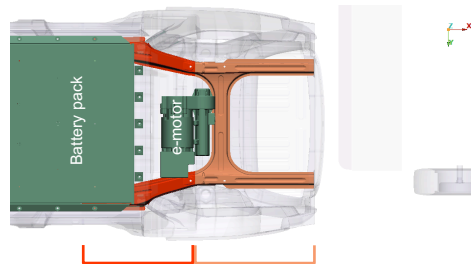

No contact on battery pack & fuel tank thanks to Hot Stamped Usibor®

Good energy absorption on the Hot Stamped Ductibor®

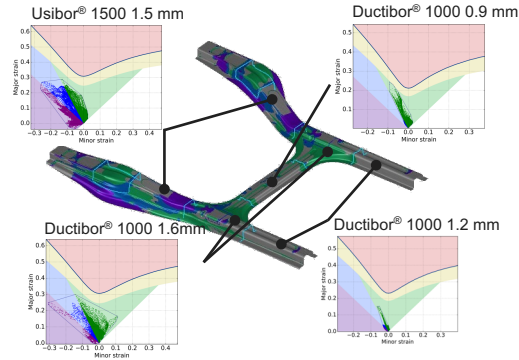

Engineering and design

Feasibility assessment (numerical)

Prototyping

ArcelorMittal Multi Part Integration™

Approach extended to the body-in-white

Main scope of MPI solutions, with deep analysis of the assembly sequence

